

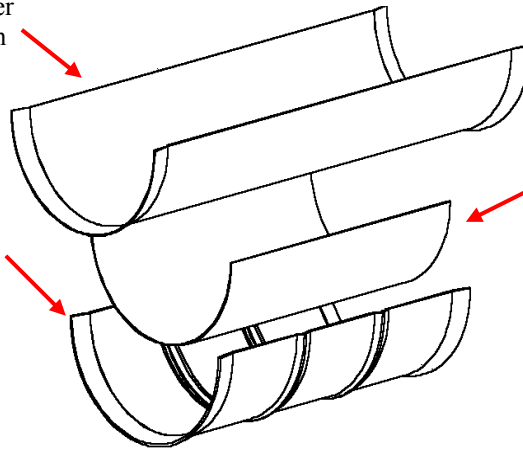

SLIDING SADDLES

Inner Saddle Adheres To Insulation Barrier and Moves With Piping, While Sliding On PTFE Surface Below

Ribbed Lower Saddle Remains Stationary On Pipe Stand, Pipe Hanger, Or Trapeze Hanger



PTFE Layer Is Laminated To Lower Saddle Providing a Low Friction Surface For Upper Saddle To Slide Against

Performance Features:

- Sliding saddles are an economical way to prevent vapor barrier and weather barrier damage caused from pipe movement
- Sliding Saddles cost less than roller systems
- Sliding Saddles require minimal labor to install versus roller systems
- PTFE (polytetrafluoroethylene) provides a low friction surface between upper and lower saddles
- High quality saddle construction helps to prevent insulation crushing
- Beveled ends help protect vapor and weather barriers against corner punctures
- Sliding Saddles help to assure longer insulation and vapor barrier life
- Sliding Saddles are available in a wide range of sizes
- Easily retro-fitted to existing insulation systems



**STOP THIS FROM HAPPENING
TO YOUR WEATHER AND
VAPOR BARRIERS**

